

OWNERS GUIDE TO INSTALLATION AND OPERATION END SUCTION CENTRIFUGAL PUMPS

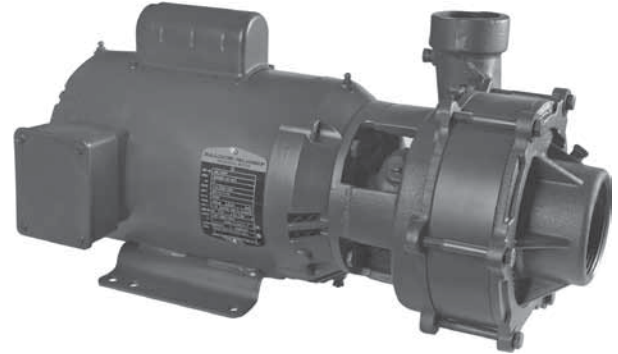

READ THESE INSTRUCTIONS CAREFULLY

Read these installation instructions in detail before installing your pump. Be sure to check the following:

1. Be certain the motor is connected for the correct line voltage being used (check motor nameplate).
2. Be certain the pump is completely primed before starting. Otherwise damage may occur to the seal.

Every pump is tested before leaving the factory, and its performance depends largely on the installation.

GENERAL SAFETY INFORMATION

1. Follow all local electrical and safety codes, as well as the National Electrical Code (NEC) and the Occupational Safety and Health Act (OSHA).
2. Replace damaged or worn wiring cord immediately.
3. Do not kink power cable and never allow the cable to come in contact with oil, grease, hot surfaces, or chemicals.
4. Protect the power cable from coming in contact with sharp objects.
5. Be careful when touching the exterior of an operating motor - it may be hot enough to be painful or cause injury.
6. Make certain that the power source conforms to the requirements of your equipment.
7. Always disconnect power source before performing any work on or near the motor or its connected load. If the power disconnect point is out-of-sight, lock it in the open position and tag it to prevent unexpected application of power. Failure to do so could result in fatal electrical shock.
8. Do not handle the pump with wet hands or when standing in water as fatal electrical shock could occur. Disconnect main power before handling unit for ANY REASON!
9. Unit must be securely and adequately electrically grounded. This can be accomplished by wiring the unit to a ground metal-clad raceway system or by using a separate ground wire connected to the bare metal of the motor frame or other suitable means.
10. **WARNING:** Risk of electric shock. This pump has not been investigated for use in swimming pool areas.
11. **WARNING:** This product contains chemicals known to the State of California to cause cancer and birth defects or other reproductive harm.

INSPECTION AND STORAGE

1. Immediately upon receipt of shipment, inspect and check the shipping document and report to the Transportation Company's local agent any damage or shortage. If the unit is received sometime before it can be used, it should be inspected, re-crated and stored in a dry location.
2. Unless otherwise specifically agreed, all capacity, head and efficiency guarantees are based on factory test when handling clear, cold, fresh water at a temperature not over 85°F.

LOCATION

IMPORTANT: In installations where property damage might result from an inoperative or leaking pump due to power outages, discharge line blockage or any other reason, a back-up system(s) and/or warning system(s) should be used.

1. Locate pump as close to the fluid source as possible.

CAUTION: *The unit should be placed where the motor and electrical components are protected from the weather and extremes of heat, humidity and below freezing temperatures.*

2. Mount unit in a dry location that is easily accessible for inspection and maintenance. Allow ample clearance around the unit for free air circulation. If a dry location is not available mount it on a foundation well above the wet floor.

WARNING: *Do not handle the pump with wet hands or when standing in water as fatal electrical shock could occur. Disconnect main power before handling unit for ANY REASON!*

3. Pumps incorporate a discharge port on the pump casing that can be adjusted in 90° increments. If necessary adjust the discharge port to accommodate the specific application. Pump performance will not be affected by the position of the discharge port.

DIMENSIONS in INCHES

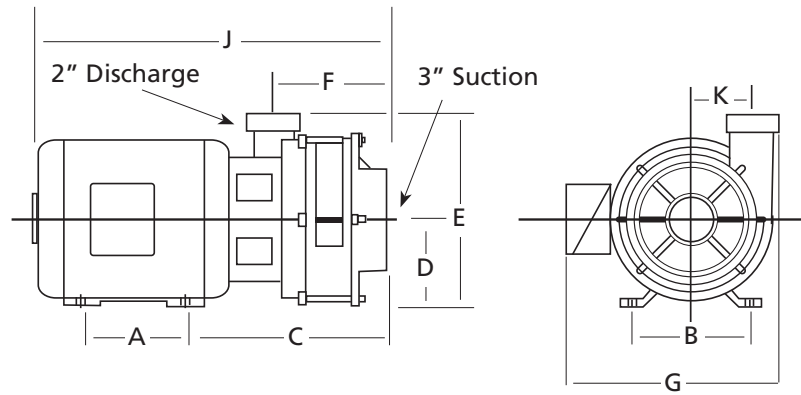

IL1000

Figure 1

C22000 SERIES

Catalog Number		HP	Motor Frame Size	A	B	C	D	E	F	G	J	K
1 Phase	3 Phase											
SINGLE STAGE 3500 RPM												
C22131	—	3	182JM	4.50	7.50	10.24	4.50	10.81	4.06	12.12	19.49	3.44
—	C22133	3	145JM	5.00	5.50	9.49	3.50	9.81	4.06	10.50	17.87	3.44
C22151	—	5	184JM	5.50	7.50	10.24	4.50	10.81	4.06	12.12	20.49	3.44
—	C22153	5	182JM	4.50	7.50	10.24	4.50	10.81	4.06	12.12	20.49	3.44
TWO STAGE 3500 RPM												
C22231	—	3	182JM	4.50	7.50	12.49	4.50	10.81	6.31	12.12	20.49	3.44
—	C22233	3	145JM	5.00	5.50	11.74	3.50	9.81	6.31	10.50	20.12	3.44
C22251	—	5	184JM	5.50	7.50	12.49	4.50	10.81	6.31	12.12	22.74	3.44
—	C22253	5	182JM	4.50	7.50	12.49	4.50	10.81	6.31	12.12	22.74	3.44
—	C22273	7-1/2	184JM	5.50	7.50	12.49	4.50	10.81	6.31	12.12	22.74	3.44

Dimensions shown above are approximate maximum dimensions for standard pumps equipped with open drip proof motors.

SUCTION LIMITATIONS

- Units are non self-priming. Normally after being primed the total suction lift of the pump is 15 feet.
- Where liquids at or near their boiling points are being handled, the supply must be located above the suction, so that the available NPSH will be greater than that required by the unit.

PIPING

- Do not use the pump as support to the piping. The pipe must be independently supported near the pump so that no strains will be transmitted to the unit. Failure to do so will cause premature pump failure and will void the warranty.
- Suction and discharge sizes are selected for proper performance of the pumping unit and are not intended to determine the suction and discharge pipe sizes. Pipe sizes must be determined by the user based on the system requirements.
- Install both a union and a gate valve (not furnished) on the suction and discharge side of the pump for service convenience.

CAUTION: Do not use a globe or other restricting type of valve at the discharge. Globe valves seriously restrict the capacity of the pump.

- All joints and connections should have pipe sealing compound (male threads only) applied and drawn up tightly.

CAUTION: The entire system must be air and water tight for efficient operation.

SUCTION PIPING

- Suction piping should be short in length, as direct as possible, and never smaller in diameter than the pump suction opening.
- Use galvanized piping, rigid plastic or other suitable pipe that will not collapse under suction.
- The suction pipe should slope upward to the pump inlet. A horizontal suction line must have a gradual rise to the pump. Any high point in the pipe will become filled with air and thus prevent proper operation of the pump. When reducing the piping to the suction opening diameter use an eccentric reducer with the eccentric side down to avoid air pockets. Never use a straight taper reducer in a horizontal suction line, as it tends to form an air pocket in the top of the reducer and the pipe.

Valves in Suction Piping

- If the pump is operating under static suction lift conditions, a foot valve may be installed in the suction line to avoid the necessity of priming each time the pump is started.

- When foot valves are used, or where there are other possibilities of "liquid hammer," close the discharge valve before shutting down the pump.
- The pump must never be throttled by the use of a valve on the suction side of the pump. Valves should be used only to isolate the pump for maintenance purposes, and should always be installed in positions to avoid air pockets.

DISCHARGE PIPING

On long horizontal runs it is desirable to maintain as even a grade as possible. Avoid high spots, such as loops, which will collect air and throttle the system or lead to erratic pumping.

Valves In Discharge Piping

A check valve and gate valve should be installed in the discharge. The check valve, placed between the pump and the gate valve, protects the pump from excessive pressure, and prevents liquid from running back through the pump in case of power failure. The gate valve is used in priming and starting, and when shutting the pump down.

Pressure Gauges

Properly sized pressure gauges can be installed in both the suction and discharge openings in the gauge taps which are provided. The gauges will enable the operator to easily observe the operation of the pump, and also determine if the pump is operating in conformance with the performance curve. If cavitation, vapor binding or other unstable operation should occur, widely fluctuating discharge pressure will be noted.

ELECTRICAL CONNECTIONS

GROUNDING

- To reduce the risk of electric shock. The motor must be securely and adequately grounded to a grounded metal raceway system or by using a separate grounding wire connected to bare metal on the motor frame, or to the grounding screw located inside motor terminal box, or other suitable means. Refer to National Electric Code (NEC Article 250 [Grounding]) for additional information.
- All wiring should be preformed by a qualified electrician and in accordance with the National Electric Code, Local Electric Codes and the Occupational Safety and Health Act (OSHA).

WARNING: Failure to connect the motor frame to equipment grounding conductor by using green screw may result in serious electrical shock.

WIRING CONNECTIONS

- This unit is not water proof and is not intended to be used in showers, saunas, or other potentially wet locations. The motor is designed to be used in a clean dry location with access to an adequate supply of cooling air. Ambient temperature around the motor should not exceed 104°F (40°C). For outdoor installations motor must be protected by a cover that does not block airflow to and around the

motor. This unit is not weatherproof nor is it able to be submersed in water, or any other liquid.

- Motor voltages will vary depending upon the motor horsepower, phase and manufacturer. Refer to the motor nameplate for voltage and electrical data.

WARNING: Make certain that the power supply conforms to the electrical specifications of the motor supplies. Failure to do so may cause premature motor failure and will void the warranty.

- For proper electrical connections, refer to the connection diagram located on the nameplate or inside the terminal box of the motor. Make sure connections are correct for the voltage being supplied to the motor.
- Whenever possible, the pump should be powered from a separate branch circuit of adequate capacity to keep voltage drop to a minimum during starting and running. For longer runs, increase wire size in accordance with the Wire Selection Guide. (See Figures 3 & 4)

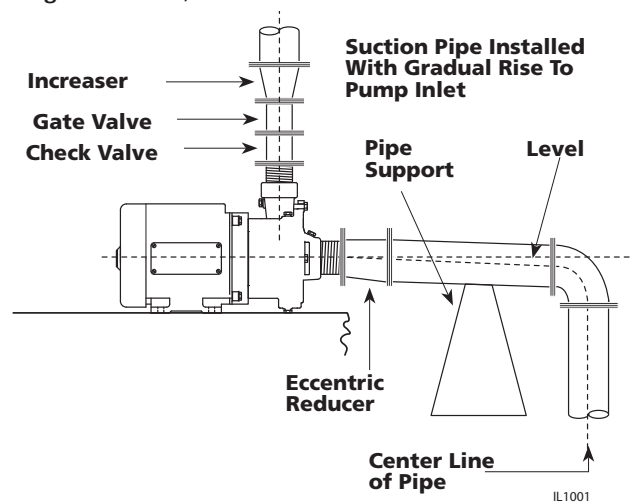

Figure 2

NOTE: Wire charts are for reference only. Consult local and state codes for approved wire sizes.

WARNING: Always disconnect power source before performing any work on or near the motor or its power source. Failure to do so could result in personal injury or fatal electrical shock.

SINGLE PHASE						
Distance From Motor To Fuse Box Meter, or Electrical Outlet		Recommended Copper Wire Size				
		1HP	1-1/2 HP	2 HP	3 HP	5 HP
100 ft.	115V	10	8	8	*	-
	230V	14	12	10	8	6
150 ft.	115V	6	6	4	*	-
	230V	12	12	10	8	4
200 ft.	115V	6	6	4	*	-
	230V	12	10	8	6	4
300 ft.	115V	*	*	*	*	-
	230V	12	6	6	4	2
500 ft.	115V	*	*	*	*	-
	230V	10	4	4	2	0

(*) Not economical to run at 115V, use 230V.

Figure 3

THREE PHASE							
Distance From Motor To Fuse Box Meter, or Electrical Outlet		Recommended Copper Wire Size					
		1HP	1-1/2 HP	2 HP	3 HP	5 HP	7-1/2 HP
100 ft.	230V	14	12	12	12	10	8
	460V	14	12	12	12	12	12
150 ft.	230V	14	12	12	12	10	8
	460V	14	12	12	12	12	12
200 ft.	230V	14	12	12	12	10	8
	460V	14	12	12	12	12	12
300 ft.	230V	12	12	10	8	6	4
	460V	14	12	12	12	10	10
500 ft.	230V	10	10	8	6	4	2
	460V	14	12	12	10	8	8

Figure 4

MOTOR PROTECTION

WARNING: Never examine, make wiring changes or touch the motor before disconnecting the main electrical supply switch.

1. Motors may or may not have built-in thermal overload protection depending upon the horsepower size, phase, type and motor manufacturer. Refer to the motor nameplate for overload protection information. It is recommended that a properly sized magnetic or manual starter (both with properly sized heaters) be used with all motors. Install starters following instructions of the starter manufacturer. See Figure 8 & 9 for magnetic starter wiring diagram. See Figures 5, 6 & 7 for motor diagrams.
2. All motors (single and three phase) should be equipped with a correctly fused disconnect switch to provide protection. Consult Local or National Electrical Codes for proper fuse protection based on motor nameplate.
3. Under size wiring can cause motor failure (low voltage), frequent cut-out of motor overload protector, television interference and even fire. Make certain the wiring is adequately sized (Figure 3 & 4), well insulated and connected to a separate circuit outside the building in case of fire.

3 Phase

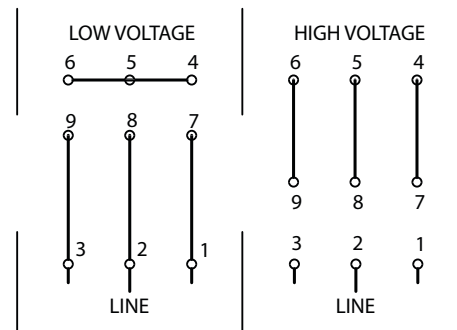

IL1229

Figure 5 - Wiring Diagram for Baldor TEFC 3 Phase motors

3 Phase

1 Phase

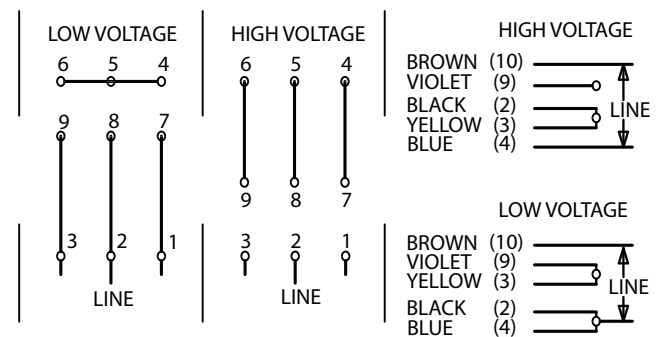

IL 1230

Figure 6 - Wiring Diagram for Franklin Electric TEFC 1 Phase and 3 Phase motors

3 Phase

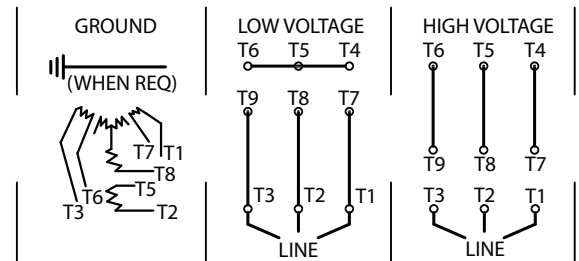

IL1231

Figure 7 - Wiring Diagram for Marathon TEFC 3 Phase motors

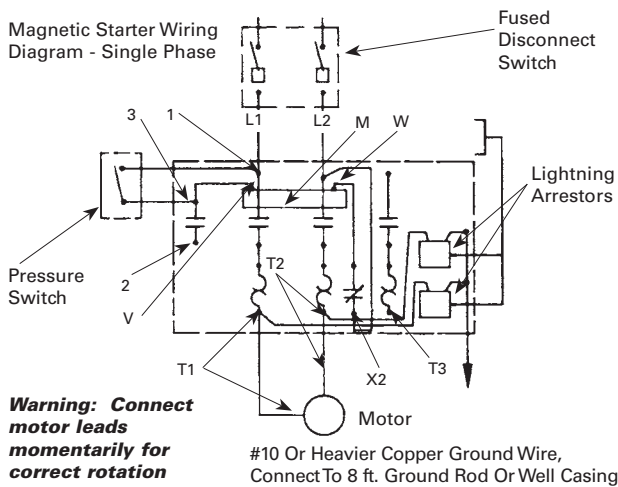

Figure 8

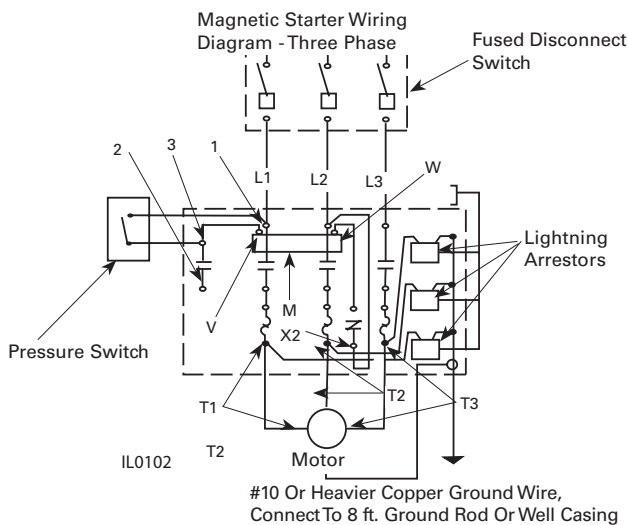

Figure 9

OPERATION

PRIOR TO STARTING

Before the pump is started initially, make the following inspections:

- Check Rotation - Be sure that the pump operates in the direction indicated by the arrow on the pump casing, as serious damage can result if the pump is operated with incorrect rotation. Rotation is always counterclockwise facing the pump suction. Operating the pump in reverse rotation may cause extensive damage.
- Check all connections to motor and starting device with wiring diagram. Check voltage, phase and frequency on motor nameplate with line circuit.

ALL PUMPS WITH 3 PHASE MOTORS MUST BE INSTALLED WITH A MAGNETIC STARTER WHICH PROVIDES 3-LEG PROTECTION FOR MOTOR. FAILURE TO USE CORRECT STARTER WILL VOID THE WARRANTY.

PRIMING

1. Before starting any centrifugal pump it is absolutely necessary that both the casing and suction pipe be completely filled with liquid. This priming can be accomplished by any of the following methods.

2. When the liquid supply level is above the center line of the pump, it is primed by opening the suction and discharge valves. The in flowing liquid will displace the air and fill the suction line, pump casing, and discharge line up to the level of supply.
3. Where the pump is operating with suction lift and the suction line is equipped with a foot valve, the system is filled with liquid by filling through the discharge piping.

STARTING

1. Follow the steps below in the order indicated to start pump:
 - Close gate valve in discharge line.
 - Open gate valve in suction line.
 - Turn on power to pump motor.
2. When pump is operating at full speed, immediately open the discharge gate valve slowly.
3. If the pump does not prime properly, or loses it prime during start-up it should be shut-down and the condition corrected before the procedure is repeated.

NOTE: The gate valve in the discharge line should always be closed when the pumps is started. The excessive current required by the motor to start under full load will in time cause motor trouble. A centrifugal pump primed and operated at full speed with the discharge gate valve closed usually requires much less power than when it is operating at its rated capacity and head with the discharge gate valve open.

OPERATING CHECKS

After initial start-up:

- Check the pump and piping to assure there are no leaks.
- Check and record pressure gauge readings for future reference.
- Check and record voltage, amperage per phase.

STOPPING PUMP

1. When stopping pump always close the discharge valve first.
2. Pump should never run for any length of time with both suction and discharge valves closed due to danger of building up pressures and temperatures.

MAINTENANCE

LUBRICATION

The pump and motor requires no lubrication. The ball bearings of the motor have been greased at the factory. Under normal operating conditions they should require no further greasing.

FREEZING

Drain the entire system if there is danger of freezing. A drain plug is provided at the bottom of the pump case for this purpose.

ROTARY SHAFT SEAL

The mechanical shaft seal should be replaced if water is noticed around the motor shaft. Remove case and impeller and, using two screw drivers to pry on each side, remove seal stationary seat. Clean seat area of frame, install new stationary seat with ceramic surface facing out and slide new rotating element over shaft sleeve with hard carbon surface against ceramic seat. Be sure to keep all surfaces clean. Lubricating seal parts with water will help the installation of the seal. Reinstall impeller and pump case.

CAUTION: Make certain that the power supply is disconnected before attempting to service the unit! Failure to do so could result in personal injury or fatal electrical shock.

MOTOR

Keep motor clean and dry. It is drip-proof when installed horizontally and the windings are protected from excess humidity, but extreme conditions should be avoided when possible. If motor fails to run, be sure power is on, all switches or electrical controls are closed, fuses are in order and all electrical connection are tight. (Motor must be repaired by Authorized Repair Station under terms of guarantee.)

PROPERTIES OF WATER			
Temperature °F	Absolute Vapor Pressure		Specific Gravity
	PSI	Ft. Water	
60	0.26	0.59	0.999
85	0.60	1.4	0.996
100	0.95	2.2	0.993
120	1.69	3.9	0.989
130	2.22	5.0	0.986
140	2.89	6.8	0.983
150	3.72	8.8	0.981
160	4.74	11.2	0.977
170	5.99	14.2	0.974
180	7.51	17.8	0.970
185	8.38	20.0	0.969
190	9.34	22.3	0.966
195	10.38	24.9	0.964
200	11.53	27.6	0.963
202	12.01	28.8	0.962
204	12.51	30.0	0.961
206	13.03	31.2	0.960
208	13.57	32.6	0.960
210	14.12	33.9	0.959
212	14.70	35.4	0.958
214	15.29	37.0	0.957
216	15.90	38.4	0.956
218	16.54	40.0	0.956
220	17.19	41.6	0.955
222	17.86	43.3	0.954
224	18.56	45.0	0.953
226	19.28	46.8	0.953
228	20.02	48.6	0.952
230	20.78	50.5	0.951
240	24.97	61.0	0.947
250	29.83	73.2	0.943
300	67.00	168.6	0.918
350	134.60	349.0	0.891

FAILURE TO PUMP

If the motor runs, but no water is pumped, be sure pump is primed, that there are no air leaks in suction piping, that all gate valves are open and all check valves operate.

NET POSITIVE SUCTION HEAD (NPSH)

NPSH combines all of the factors limiting the suction side of a pump; internal pump losses, static suction lift, friction losses, vapor pressure and atmospheric conditions. It is important to differentiate between REQUIRED NPSH and AVAILABLE NPSH.

NPSH REQUIRED

REQUIRED NPSH is a factor designed into a pump and measurable in the test laboratory by the manufacturer. Testing facilities can determine losses in the suction piping, static lift and barometric pressures.

NPSH AVAILABLE

1. The term for providing sufficient pressure on the suction, at the impeller eye, to prevent "boiling" is known as NPSH AVAILABLE. It is a function of the pumping system and consists of pressure on the liquid at its source, the elevation of the liquid with respect to the impeller center line, losses in the suction piping and vapor pressure of the liquid.

Altitude (Feet)	Barometer Inches Mercury	Atmospheric Pressure		Boiling Point °F
		PSIA	(ft. water)	
-1000	31.0	15.2	32.5	213.8
-500	30.5	15.0	34.6	212.9
0.0	29.9	14.7	33.9	212.0
+500	29.4	14.4	33.3	211.1
+1000	28.9	14.2	32.8	210.2
+1500	28.3	13.9	32.1	209.3
+2000	27.8	13.7	31.5	208.4
+2500	27.3	13.4	31.0	207.4
+3000	26.8	13.2	30.4	206.5
+3500	26.3	12.9	29.8	205.6
+4000	25.8	12.7	29.2	204.7
+4500	25.4	12.4	28.8	203.8
+5000	24.9	12.2	28.2	202.9
+5500	24.4	12.0	27.6	201.9
+6000	24.0	11.8	27.2	201.0
+6500	23.5	11.5	26.7	200.1
+7000	23.1	11.3	26.2	199.2
+7500	22.7	11.1	25.7	198.3
+8000	22.2	10.9	25.2	197.4
+8500	21.8	10.7	24.7	196.5
+9000	21.4	10.5	24.3	195.5
+9500	21.0	10.3	23.8	194.6
+10000	20.6	10.1	23.4	193.7
+15000	16.9	8.3	19.2	184.0

2. If the available NPSH is not equal to, or greater than that required by the pump, it must be increased. This is usually done by increasing the static head, Hz.

NPSH FORMULAS

PROPOSED INSTALLATION

- To calculate the NPSH available in a proposed application, the following formula is recommended:

$$H_{sv} = H_p \pm H_z - H_f - H_{vp}$$
- H_{sv} -Available NPSH expressed in feet of fluid
- H_p -Absolute pressure on the surface of the liquid where the pump tanks suction, expressed in feet. This

- could be atmospheric pressure or vessel pressure (pressurized tank).
- H_z -Static elevation of the liquid above, or below the center line of the impeller, expressed in feet.
 - H_f -Friction and entrance head loss in the suction piping, expressed in feet.
 - H_{vp} -Absolute vapor pressure of the fluid at the pumping temperature, expressed in feet of fluid.

Troubleshooting Chart		
Symptom	Possible Cause(s)	Corrective Action
Low or no discharge	<ol style="list-style-type: none"> Incorrect rotation Insufficient inlet pressure or suction head (NPSH Required) Total head too high Leak in suction line Impeller clogged or damaged Wrong size piping Casing gasket leaking Suction or discharge line valves closed Mechanical seal leaking 	<ol style="list-style-type: none"> Refer to wiring diagram Increase inlet pressure by adding more fluid to fluid source. (See Spec's for minimum NPSH Required) Lower discharge head Repair or replace Clean or replace Make needed adjustments Replace gasket Open Replace
Loss of suction	<ol style="list-style-type: none"> Insufficient inlet pressure or suction head (NPSH Required) Clogged strainer 	<ol style="list-style-type: none"> Increase inlet pressure by adding more fluid to fluid source. (See Spec's for minimum NPSH Required) Clean or replace
Pump vibrates and/or makes excessive noise	<ol style="list-style-type: none"> Mounting plate or foundation not rigid enough Foreign material in pump Damaged impeller Cavitation present 	<ol style="list-style-type: none"> Reinforce Clean Replace Check suction line for proper size and be sure valve is open. Remove excessive loops in suction line. (See Spec's for minimum NPSH Required)
Pump leaks at shaft	<ol style="list-style-type: none"> Damaged or worn mechanical seal Corrosion due to character of liquid pumped 	<ol style="list-style-type: none"> Replace Discontinue pumping liquid and consult factory
Pump will not start or run	<ol style="list-style-type: none"> Improperly wired Blown fuse or open circuit breaker Loose or broken wiring Impeller clogged Motor shorted out 	<ol style="list-style-type: none"> Refer to wiring diagram Replace fuse or close circuit breaker Tighten connections and replace broken wiring Clean Replace
Motor problems	<ol style="list-style-type: none"> Various Overloading motor. Too much water delivery Liquid heavier and more viscous than water Seal binding Rotor binding Voltage and frequency lower than rating Defects in motor 	<ol style="list-style-type: none"> Consult qualified electrician Restrict outlet by closing down valve in discharge line Consult factory Replace Repair or replace Reconnect to rated voltage and frequency Repair or replace
Pinholes in the casting. Liquid drips around seal area but is not seal	<ol style="list-style-type: none"> Cavitation caused by insufficient inlet pressure or suction head (NPSH Required) 	<ol style="list-style-type: none"> Increase inlet pressure by adding a higher level of fluid to source or increasing inlet pressure. (See Spec's for minimum NPSH Required)

CENTRIFUGAL PUMP REPAIR PARTS "C22000" SERIES (For Pricing Refer To Repair Parts Price List)

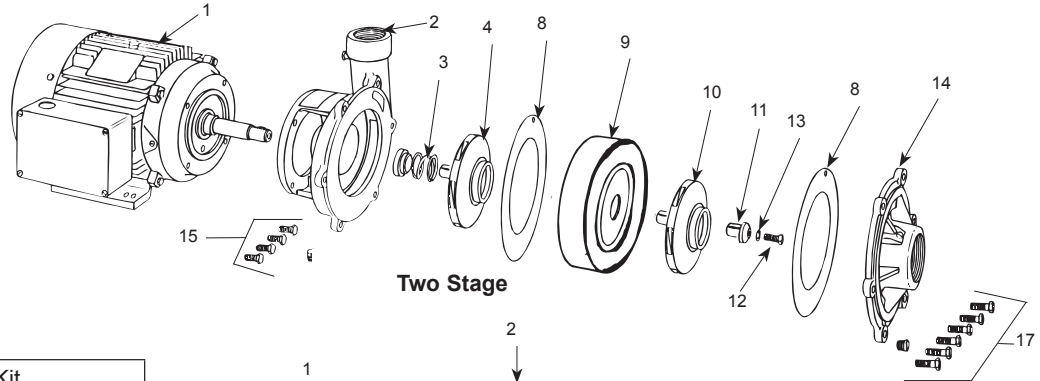

Two Stage

021434 Repair Kit Kit Includes:		
Qty.	Item No.	Part No. & Description
1	3	136559 Seal Assembly
1	•	136576 O-Ring, Cap Screw
1		136572 O-Ring, Impeller
1		136569 O-Ring, Impeller
2	8	124638 Gasket

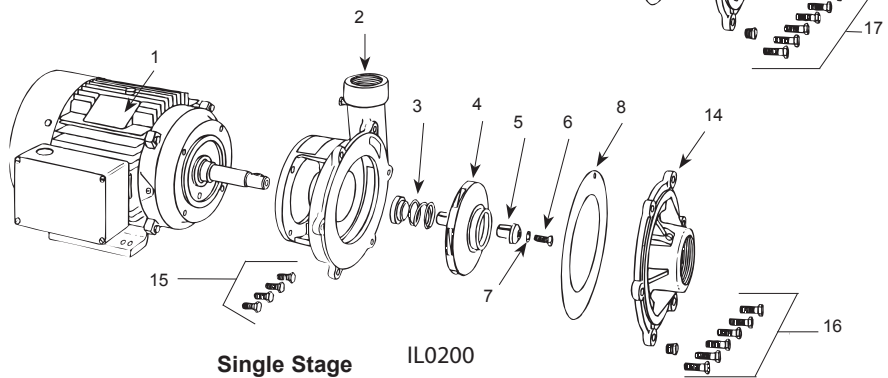

Single Stage

IL0200

Product may not be exactly as shown.

ITEM	DESCRIPTION	HORSEPOWER		PART NUMBER		
		3	5	3	5	7-1/2
		1	1	2	2	2
		C22131	C22151	C22231	C22251	—
		3	5	3	5	7-1/2
		C22133	C22153	C22233	C22253	C22273
1	Motor — 1 Phase	134962	134963	134962	134963	—
1	Motor — 3 Phase	134965	134966	134965	134966	134967
2	Mounting Ring	136556	136556	136556	136556	136556
3	Seal Assembly	136559	136559	136559	136559	136559
	• Key 3/16 x 27/32"	136560	136560	—	—	—
	• Key 3/16 x 2-1/32"	—	—	134977	134977	134977
4	Impeller	136561	136562	136563	136565	136567
	• O-Ring, Impeller	136569	136569	136569	136569	136569
5	Retainer, Impeller	136570	136570	—	—	—
6	Cap Screw 1" Long	136573	136573	—	—	—
	• O-Ring, Cap Screw	136576	136576	—	—	—
7	Lock Washer 3/8" S.S.	120649	120649	—	—	—
8	Gasket	124638 (1)	124638 (1)	124638 (2)	124638 (2)	124638 (2)
9	Intermediate Stage w/Clearance Ring	—	—	136578	136578	136578
	• Clearance Ring - Large	—	—	125176	125176	125176
	• Clearance Ring - Small	—	—	136577	136577	136577
10	Impeller (Front)	—	—	136564	136566	136568
11	Retainer, Impeller	—	—	136571	136571	136571
	• O-Ring, Impeller	—	—	136572	136572	136572
12	Cap Screws 2-1/4" Long	—	—	136575	136575	136575
	• O-Ring, Cap Screw	—	—	136576	136576	136576
13	Lock Washer 3/8" S.S.	—	—	120649	120649	120649
14	Suction Flange Assembly w/Clearance Ring	023089	023089	023089	023089	023089
	• Clearance Ring	125176	125176	125176	125176	125176
	• Pipe Plug 1/4" NPT	* (4)	* (4)	* (5)	* (5)	* (5)
15	Hex Hd. Cap Screws 3/8 x 1"	* (4)	* (4)	* (4)	* (4)	* (4)
16	Hex Hd. Cap Screws 3/8 x 1-1/4"	* (6)	* (6)	—	—	—
17	Hex Hd. Cap Screws 3/8 x 3-1/4"	—	—	* (6)	* (6)	* (6)

(*) Standard hardware item
(•) Not shown